

ACO Drain® | KlassikDrain

K2-621 Catch Basin w/ Plastic Base

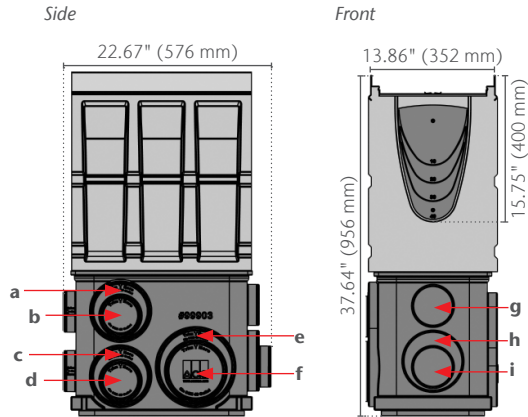

K2-621 (K200)
part no. 94620



Catch Basin Outlet	Size (SCH 40)	Invert in	GPM	CFS
a	6.00"	29.15	626	1.40
b	4.00"	28.59	281	0.63
c	6.00"	36.28	707	1.57
d	4.00"	35.72	316	0.70
e	8.00"	36.28	1237	2.76
f	6.00"	35.72	701	1.56
g	4.00"	27.65	276	0.61
h	6.00"	34.78	690	1.54
i	4.00"	34.36	310	0.69

K2-621 (KS200)
part no. 94621

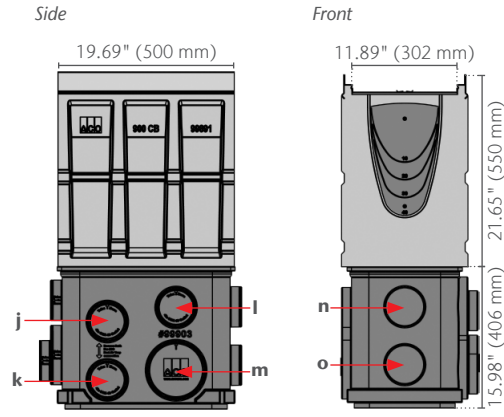

Catch Basin Outlet	Size (SCH 40)	Invert in	GPM	CFS
j	4.00"	29.80	287	0.64
k	4.00"	36.29	319	0.71
l	4.00"	28.22	279	0.62
m	6.00"	36.29	707	1.57
n	4.00"	28.37	280	0.62
o	4.00"	34.87	312	0.70

Note: These are pipe flow rates at specified outlets, NOT channel flow rates. Catch basin flow rates are listed without a trash bucket—using a trash bucket reduces flow.

Trash Bucket
included with K2-621

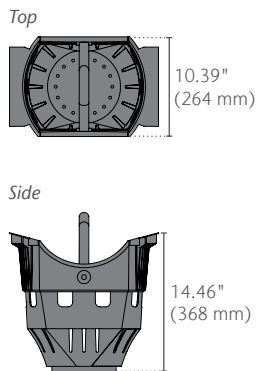

Foul Air Trap (optional)
part no. 90854

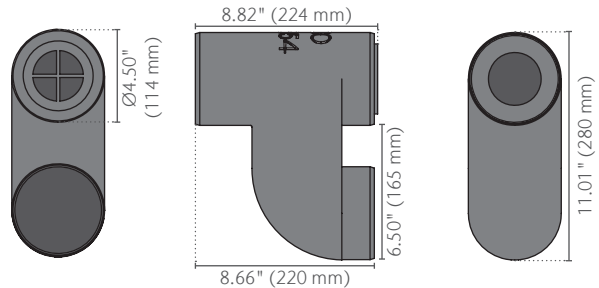

K2-621 Catch Basin w/ Plastic Base



Product Name	Part No.	Volume* gal	Weight lbs
K2-621 Catch Basin w/ Plastic Base (K200)	94620	24.9	91.0
K2-621 Catch Basin w/ Plastic Base (KS200)	94621	24.9	91.0
Foul Air Trap	90854	-	1.2

*Volume is up to grate seat and without trash bucket.

Specification Summary

General

The catch basin shall be ACO Drain K2-621 Catch Basin, comprising of a top section, trash bucket and base as manufactured by ACO, Inc. or similar approved.

Grates

Grates shall be specified. See separate ACO Spec Info grate sheets for details. After removal of grates and QuickLok® bar there shall be uninterrupted access to the catch basin to aid maintenance. Accepts all 0.5 m ACO K200 DrainLok grates or K200 QuickLok grates with optional QuickLok bar.

Installation

The trench drain/catch basin system shall be installed in accordance with the manufacturer's installation instructions and recommendations.

Materials

The catch basin top section shall be manufactured from polymer concrete with the minimum properties as follows:

- Compressive strength: 13,053 psi
- Flexural strength: 3,191 psi
- Water absorption: 0.07%
- Resistant to dilute acid and alkali
- Frost-proof
- Salt-proof

The nominal clear opening shall be 11.89" (302 mm) wide by 19.69" (500 mm) long. Type K2-621 catch basin assembly has overall depth of 37.64" (956 mm). Polymer concrete top units shall incorporate a cast in a galvanized or stainless steel frame manufactured with drillouts for channel connection and have a wall thickness of at least 0.59" (15 mm). Top units shall have horizontal cast in anchoring key features on the outside to ensure maximum mechanical bond to the surrounding bedding material and pavement surface. The base unit shall be an LLDPE plastic molding and incorporate molded plastic pipe stubs to facilitate pipe connection. The trash bucket shall be a polypropylene plastic molding.



EN1433 Load Class E
134,885 lbs – 2,785 psi

ACO, Inc.

© January 2026 ACO, Inc.

All reasonable care has been taken in compiling the information in this document. All recommendations and suggestions on the use of ACO products are made without guarantee since the conditions of use are beyond the control of the company. It is the customer's responsibility to ensure that each product is fit for its intended purpose and that the actual conditions of use are suitable. ACO, Inc. reserves the right to change products and specifications without notice.

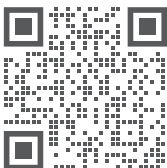

info@acousa.com
www.acousa.com

